



Features

- Analog Audio over Fiber
- Singlemode Options (up to 70 km)
- Multimode Options (up to 2 km)
- TDM - Single Wavelength
- No EMI, RFI, or Ground Loops
- 3-Year Warranty

Applications

- High-Quality Video Security Systems
- Video Surveillance
- Train/Rail Station Camera Systems
- CCTV Applications

Analog Audio Transmission

The Optiva OTP-4BA provides for the transmission of 4 channels of analog audio, over long or short distances, using a single fiber.

In addition, the OTP-4BA is part of our innovative Optiva video, audio and data media transport system. Optiva was designed to maintain lossless fiber extension between input and output signals. New signals may be added without the need for additional fiber through our proprietary daisy-chain technology. The Optiva line of products also includes insert cards for up to 16 channels of multiplexing / demultiplexing, 16x16 matrix switching, optical add / drop, as well as remote system monitoring.

System Design

Optiva insert cards support both 19" rackmount and compact tabletop or wall-mountable enclosures. The 3RU 19" rackmount enclosures (Models: OT-CC-16 & OT-CC-16F) can support up to 16 insert cards as well as dual-redundant, hot-swappable power supplies utilizing two 100 watt or two 200 watt power supplies. Also available in the rackmount form factor is our 1RU enclosure (Model: OT-CC-6-1U) which can accommodate six insert cards and utilizes two 60 watt power supplies. For desktop or wall mounting applications there are one-slot (Model: OT-DTCR-1) and two-slot (Model: OT-DTCR-2) enclosures. Both use an external wall mount power supply.

optiva | PLATFORM

Enclosure Options

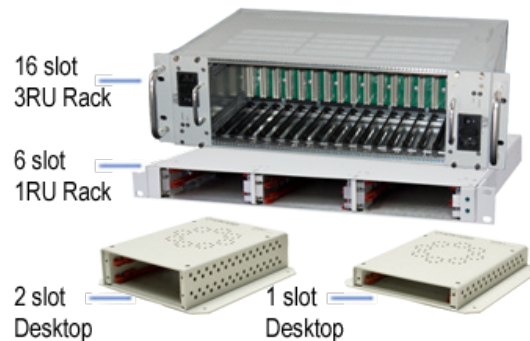

DATASHEET **FIBER OPTICS**

Models

Transmitter	Receiver
OTP-4BAT-A0-XX	OTP-4BAR-A0-XX
OTP-4BAT-A1-XX	OTP-4BAR-A1-XX
OTP-4BAT-A2-XX	OTP-4BAR-A2-XX
OTP-4BAT-A2D-XX	OTP-4BAR-A2D-XX
OTP-4BAT-A3-XX	OTP-4BAR-A3-XX
OTP-4BAT-A3D-XX	OTP-4BAR-A3D-XX
OTP-4BAT-L4x1-XX	OTP-4BAR-L4x1-XX
OTP-4BAT-NOC	OTP-4BAR-NOC

- When ordering, please substitute the "XX" in the model for one of the following optical connectors: ST, FC, SC, or LC.
- Standard SC connector type is UPC. APC is available upon request.

Optical Specifications

Code	Fiber Type	Wavelength	Optical Budget	Distance
A0	Multimode	850 nm	5 dB	0.5 km
A1	Multimode	1310 nm	7 dB	2 km
A2	Singlemode	1310 nm	5 dB	10 km
A2D	Singlemode	1310 nm	12 dB	20 km
A3	Singlemode	1550 nm	17 dB	40 km
A3D	Singlemode	1550 nm	25 dB	60 km
L4x1	Singlemode	CWDM	Varies	20-70 km

- Chromatic dispersion as well as other losses should also be taken into account
- Stated distances are the maximum range, shorter distance may require attenuation

Connection Diagram

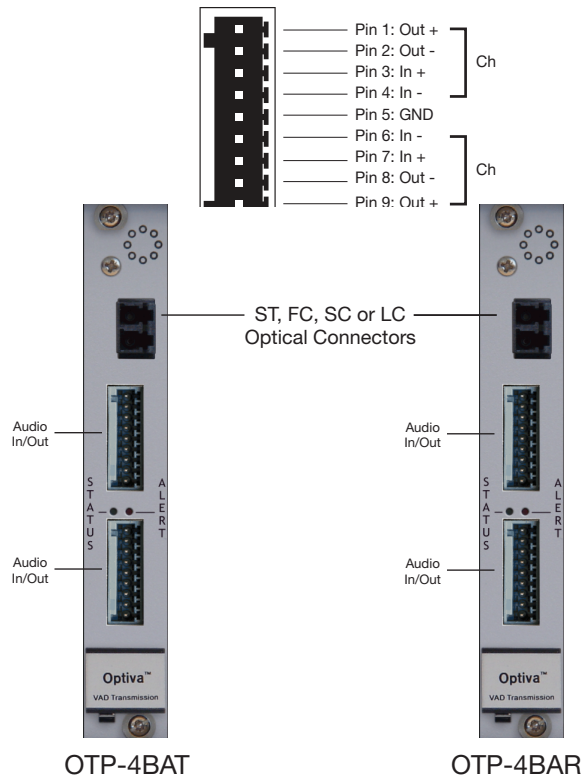

Audio

Specifications	Values
Level	18 dBm In/Out
Bandwidth	20 Hz to 20 KHz
Signal to Noise Ratio	> 80 dB
Total Harmonic Distortion	< 0.1%
Signal Coding	24-bit
Connector	Terminal Block

General

Specifications	Values
Dimensions (Insert Card)	6.69"L x 0.81"W x 5.06"H
Weight	11 oz.
Operating Temperature	-20°C to +55°C
Storage Temperature	-40°C to +85°C
Humidity	0 to 95% (Non-Condensing)
Operating Voltage	12 VDC
Power Consumption	6 Watts
Bit Error Rate	10 ⁻¹⁴
System Latency	< 1 ms
Warranty	3 year

Monitoring & Control

Specifications	Values
Local	Front panel LED status and alert indicators
Remote	OptivaView SNMP Management Suite*

- * Requires OptivaView SNMP Controller Card (Model: OPV-CTRLR)

Compliance

